

Data sheet

Hand operated regulating valves

Types REG-SA and REG-SB



REG-SA and REG-SB are angleway and straightway hand operated regulating valves, which act as normal shut-off valves in closed position.

The valves are available in two different versions – REG-SA and REG-SB designed for regulation purposes in liquid and expansion lines.

The valves are designed to meet the strict quality requirements on refrigerating installations specified by the international classification societies and are carefully designed to present favourable flow conditions and accurate linear characteristics.

REG-SA and REG-SB are equipped with vented cap and internal backseating enables replacement of the spindle seal whilst the valve is active, i.e. under pressure.

Features

- Applicable to HCFC, HFC, R717 (Ammonia), R744 (CO₂), Propane, Butane, Iso-Butane and Ethane. R717 Heat Pump and Propylene applications with replaced O-ring.
- Modular Concept:
 - Each valve housing is available with several different connection types and sizes.
 - Possible to convert REG-SA or REG-SB to any other product in the Flexline™ SVL family (shut-off valve, check & stop valve, check valve or strainer) just by replacing the complete top part.
- Fast and easy valve overhaul service. It is easy to replace the top part and no welding is needed.
- Designed to ensure perfect regulation
- Internal backseating enables replacement of the spindle seal whilst the valve is active, i.e. under pressure.
- Easy to disassemble for inspection and possible repair.
- Long neck versions (DN 15 to DN 40) for insulated systems available from parts programme.
- Max. operating pressure: 52 bar g (754 psi g)
- Temperature range: –60/+150°C (–76/+302°F)
- Acts as a normal shut-off valve in closed position.
- Housing and bonnet material is low temperature steel according to requirements of the Pressure Equipment Directive and other international classification authorities.
- Exact capacity and setting of the valve can be calculated for all refrigerants by means of Coolselector®2 (Danfoss calculation and selection software).
- Classification: DNV, CRN, BV, EAC etc. To get an updated list of certification on the products please contact your local Danfoss Sales Company.

Design
Housing

Housing is Standard SVA angleway or straightway housing allowing other inserts from the SVL platform to be installed.
Material is special, cold resistant steel

Connections

Available with the following connections:

- Butt-weld ANSI (B 36.10 Schedule 80)
– DN 10 - 40 (3/8 - 1 1/2 in.)
- Butt-weld ANSI (B 36.10 Schedule 40)
– DN 50 - 65 (2 - 2 1/2 in.)
- Socket weld (ANSI B 16.11)
– DN 15 - 40 (1/2 - 1 1/2 in.)
- FPT inside pipe thread, NPT (ANSI/ASME B 1.20.1)
– DN 15 - 32 (1/2 - 1 1/4 in.)

The cone

The valves are available in two different versions – REG-SA with an A cone and REG-SB with a B cone. The A cone is designed for expansion lines, while the B cone is designed for regulating purposes e.g. liquid lines.

The valve cone is designed to ensure perfect regulation and provide an extensive regulating area. Irrespective of the refrigerant used, it is easy to obtain the correct capacity. A cone seal ring provides perfect sealing at a minimum closing momentum.

The valve cone can be turned on the spindle, thus there will be no friction between the cone and the seat when the valve is opened and closed.

Spindle

The spindle is made of polished stainless steel, which is ideal for O-ring sealing.

Packing gland - REG-SA and REG-SB

The “full temperature range” packing gland ensures perfect tightness in the whole range: –60/+150°C (–76/+302°F). The packing glands are equipped with a scraper ring to prevent penetration of dirt and ice.

Installation

Install the valve with the spindle up or in horizontal position. The flow must be directed towards the cone.

The valve is designed to withstand high internal pressure. However, the piping system in general should be designed to avoid liquid traps and reduce the risk of hydraulic pressure caused by thermal expansion.

For further information refer to product instruction for REG-SA and REG-SB.

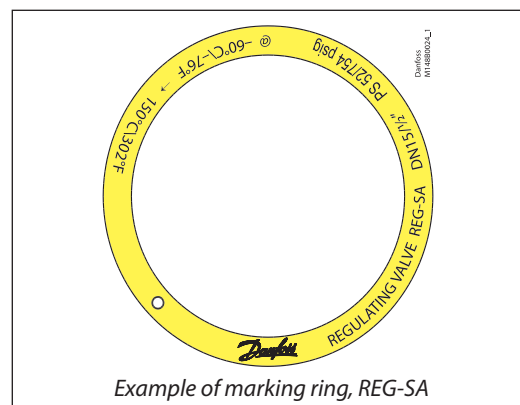

Example of marking ring, REG-SA

Pressure Equipment Directive (PED)

REG valves are approved according to the European standard specified in the Pressure Equipment Directive and are CE marked.



REG-SA and REG-SB valves			
Nominal bore	DN = < 25 mm (1 in.)	DN32-80 mm (1¼ - 3 in.)	DN100 - 125 mm (4 - 5 in.)
Classified for	Fluid group I		
Category	Article 3, paragraph 3	II	III

Technical data

- **Refrigerants**
Applicable to HCFC, HFC, R717 (Ammonia), R744 (CO₂), Propane, Butane, Iso-Butane and Ethane. R717 Heat Pump and Propylene applications with replaced O-ring.
- **Temperature range**
–60/+150°C (–76/+302°F)
- **Max working pressure**
52 bar g (754 psi g)
- **Flow coefficients**
Flow coefficients for fully opened valves from $k_v = 0.15$ to 80 m³/h ($C_v = 0.17$ to 92.5 USgal/min).

Computation and selection

Introduction

In refrigeration plants, hand operated regulating valves are primarily used in liquid lines in order to regulate the flow of refrigerant. The valves can, however, also be used as expansion valves. From a calculation point of view the two fields of application are very different.

Normal flow is the term used to describe the general case where the flow through the valve is proportional to the square root of the pressure drop across it and inversely proportional to the density of the refrigerant (Bernouillis equation).

This relationship between mass flow, pressure drop and density satisfies the majority of all valve applications with refrigerants and brines.

Normal flow is characterised by turbulent flow through the valve without any phase change. The following capacity curves are based on the above mentioned assumption.

Application of the hand operated regulating valves outside the normal flow area will reduce the capacity of the valve considerably. In such cases it is recommended to use Coolselector®2 (Danfoss calculation and selection software).

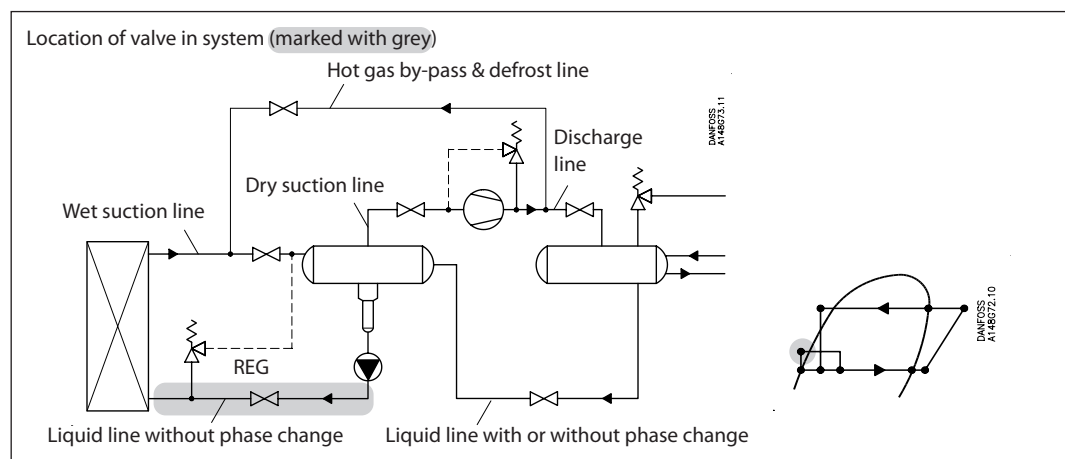

Sizing hand operated regulating valve for liquid flow

Liquid refrigerants: Use the liquid tables, fig. 6 - 10. For other refrigerants and brines, "Normal flow" (Turbulent flow); see below and use the flow coefficient tables (fig. 1 - 5).

SI-units

Mass flow:

$$k_v = \frac{G}{\sqrt{\rho \times 1000 \times \Delta p}} = G \times C_A \text{ [m}^3/\text{h]}$$

Volume flow:

$$k_v = \frac{\dot{V}}{\sqrt{\frac{1000 \times \Delta p}{\rho}}} \text{ [m}^3/\text{h]}$$

Imperial units

Mass flow:

$$C_v = \frac{0.95 \times G}{\sqrt{\rho \times \Delta p}} = 31.6 \times G \times C_A \text{ [USgal/min.]}$$

Volume flow:

$$C_v = \frac{0.127 \times \dot{V}}{\sqrt{\frac{\Delta p}{\rho}}} \text{ [USgal/min.]}$$

k_v	[m ³ /h]	Quantity [m ³ /h] of water flowing through a valve at a pressure loss of 1 bar (according to VDE/VDI Norm 2173).
P_1	[bar]	Pressure before the valve (upstream).
P_2	[bar]	Pressure after the valve (downstream).
Δp	[bar]	Actual pressure loss across the valve ($P_1 - P_2$).
G	[kg/h]	Mass flow through the valve.
\dot{V}	[m ³ /h]	Volume flow through the valve.
ρ	[kg/m ³]	Density of the refrigerant before the valve.
C_A		Calculation factor (fig. 11).

C_v	[US gal/min]	Quantity [US gal/min] of water flowing through a valve at a pressure loss of 1 psi.
P_1	[psi]	Pressure before the valve (upstream).
P_2	[psi]	Pressure after the valve (downstream).
Δp	[psi]	Actual pressure loss across the valve ($P_1 - P_2$).
G	[lb/min]	Mass flow through the valve.
\dot{V}	[US gal/min]	Volume flow through the valve.
ρ	[lb/ft ³]	Density of the refrigerant before the valve.
C_A		Calculation factor (fig. 11).

Computation and selection

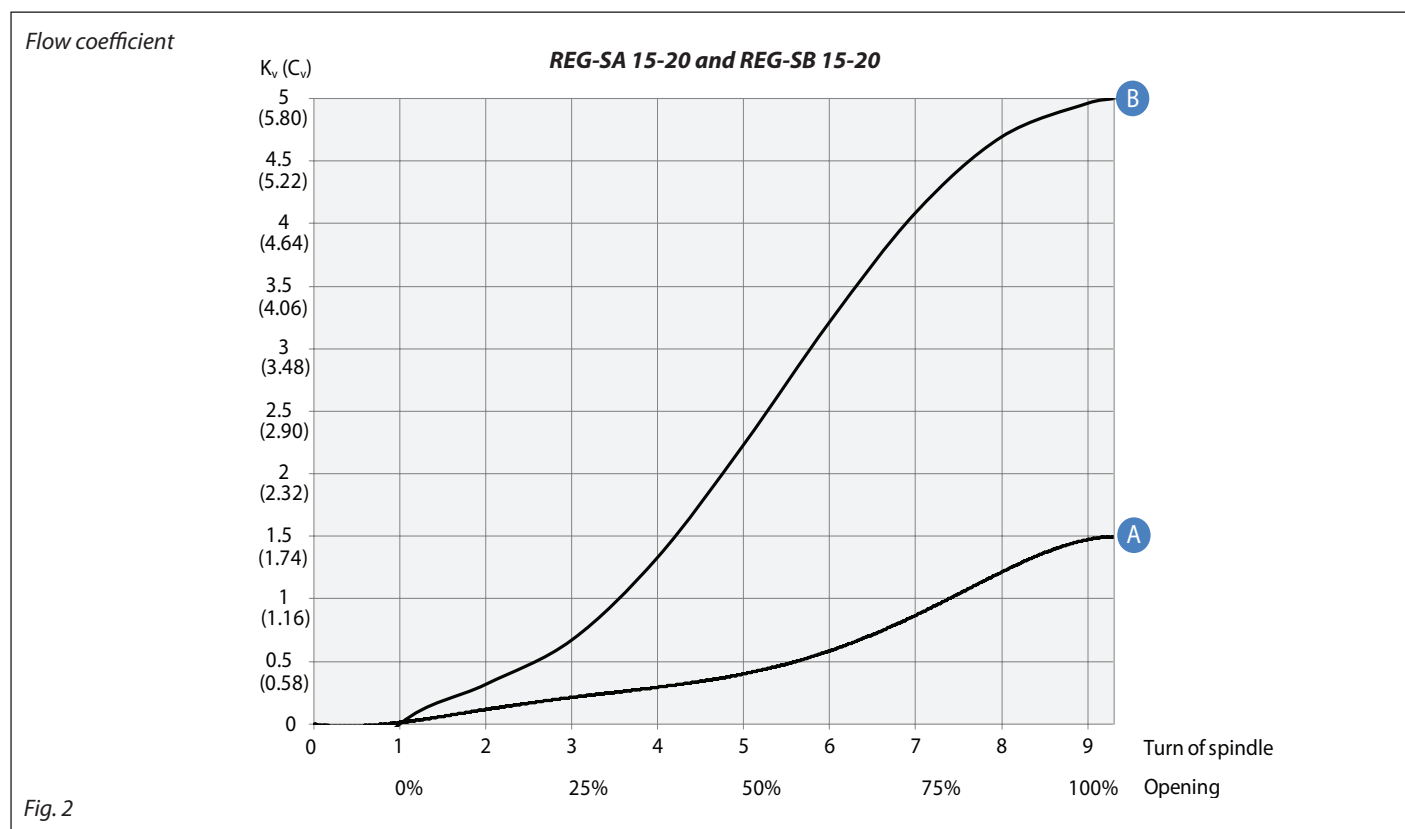
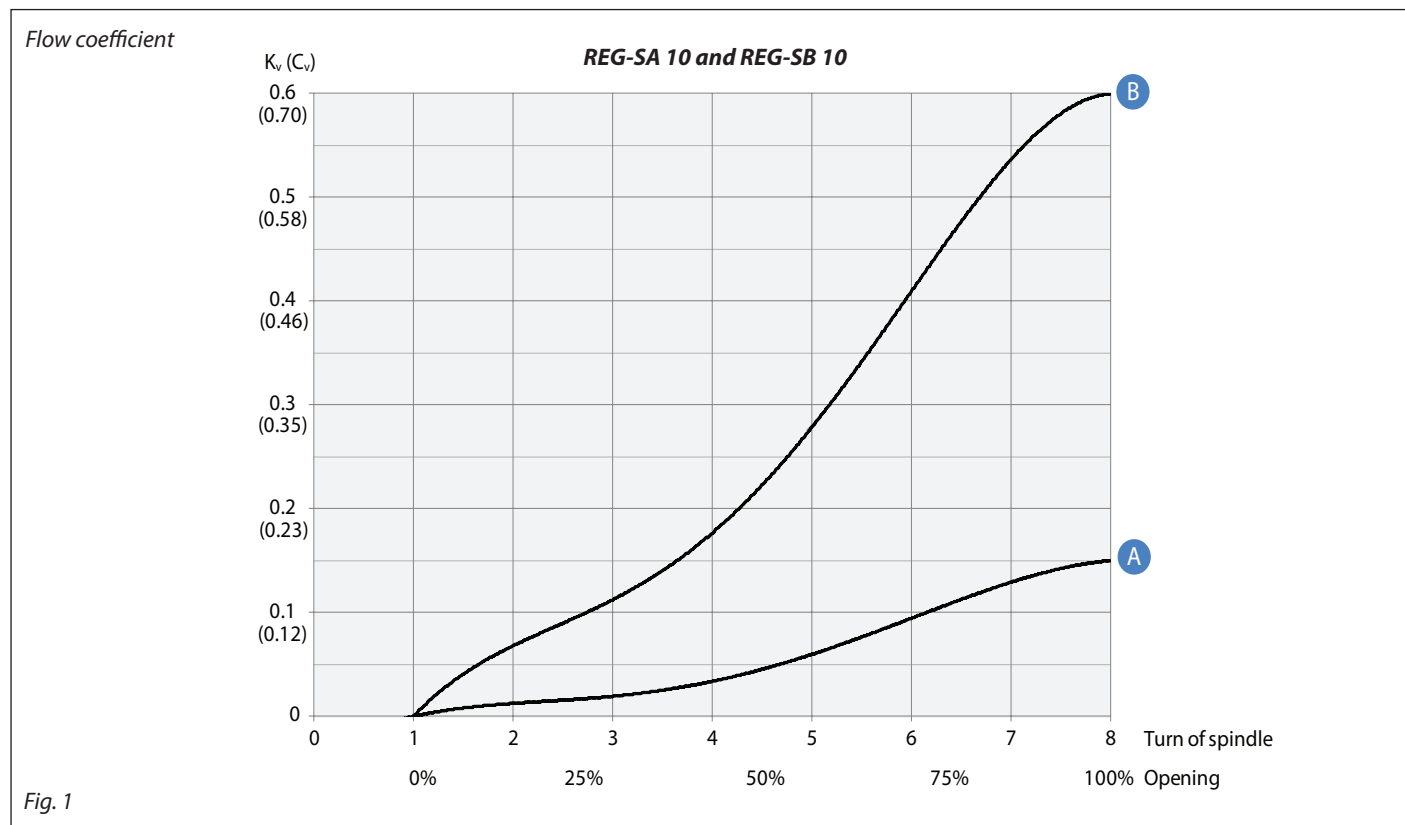

Computation and selection (Continued)

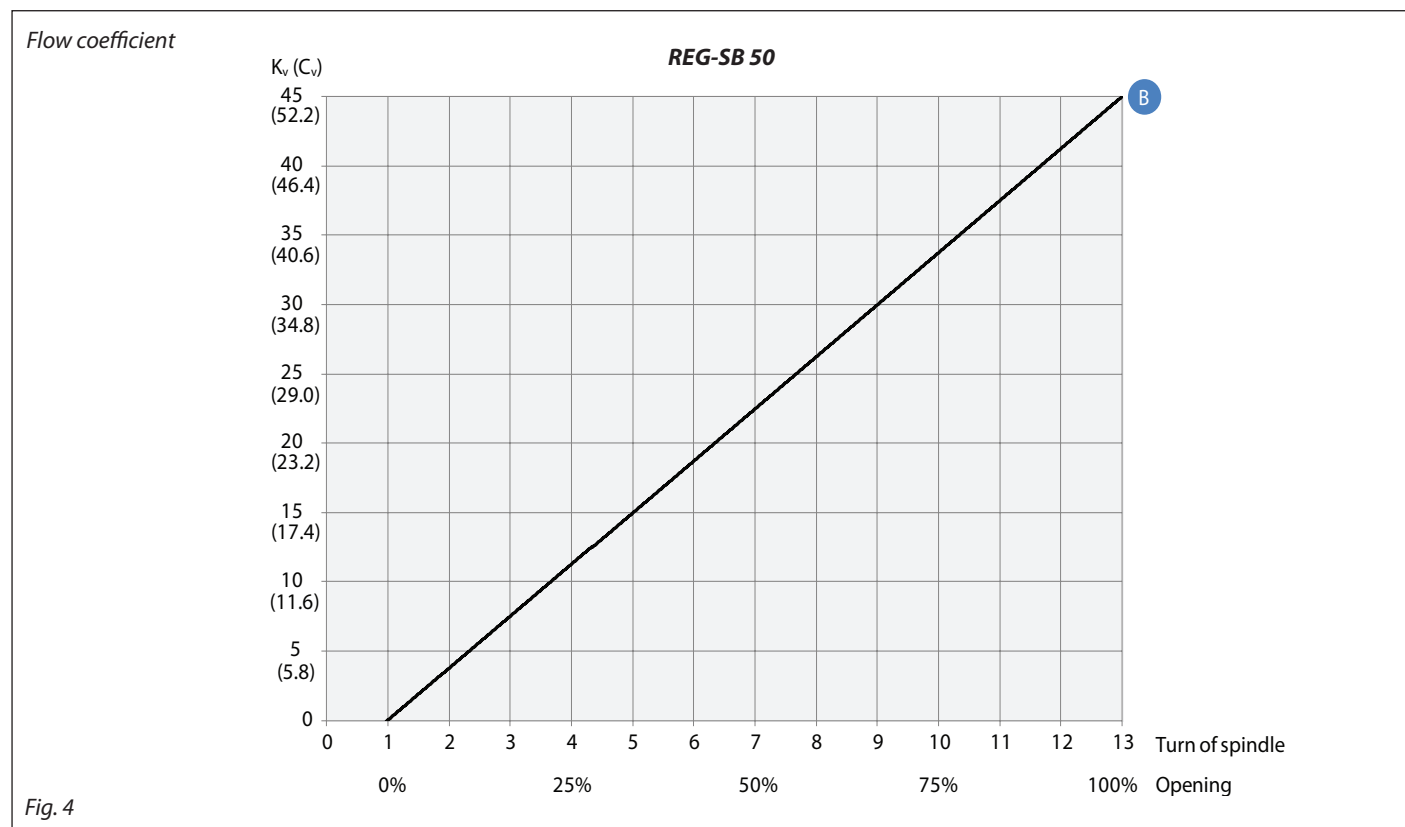
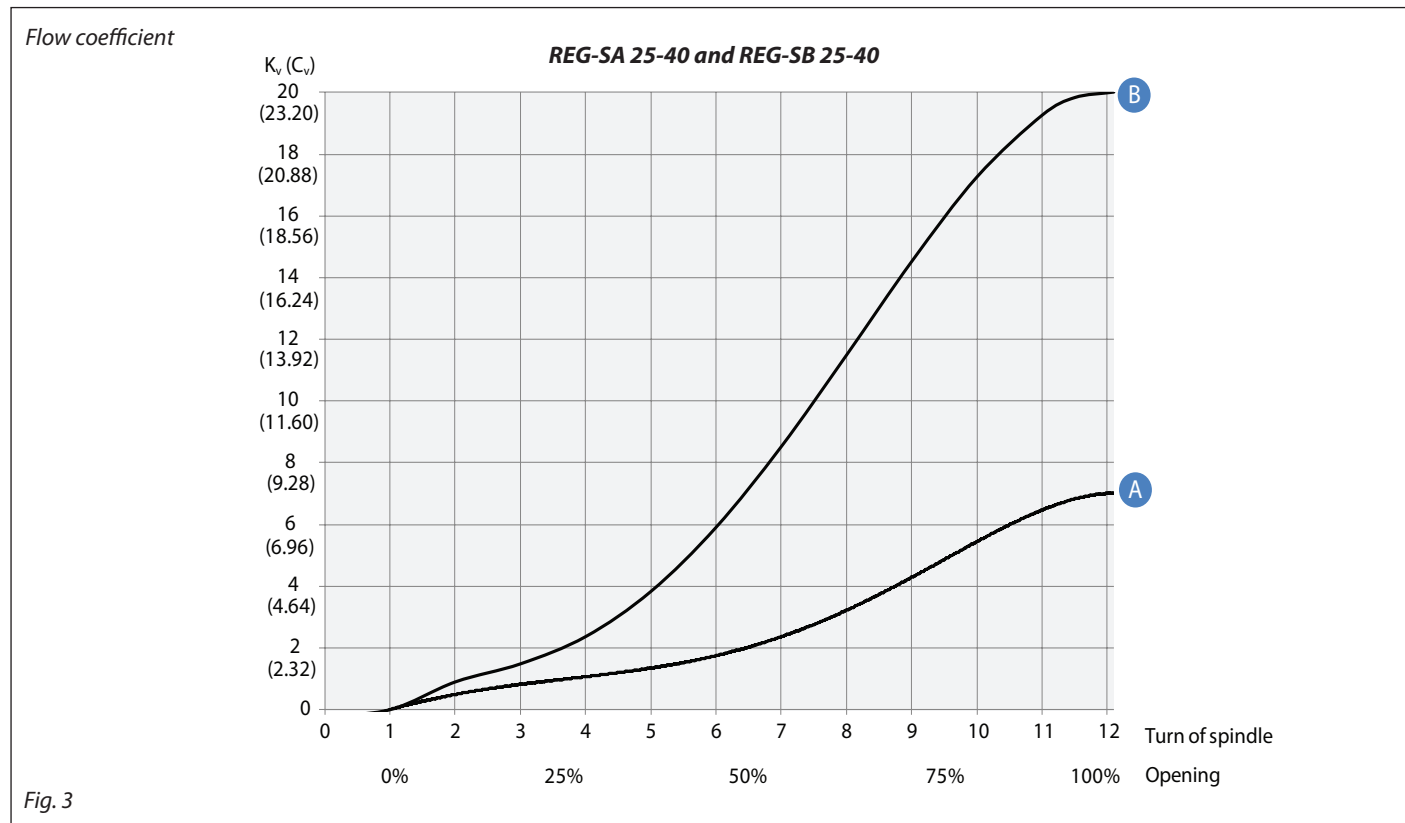

Computation and selection (Continued)

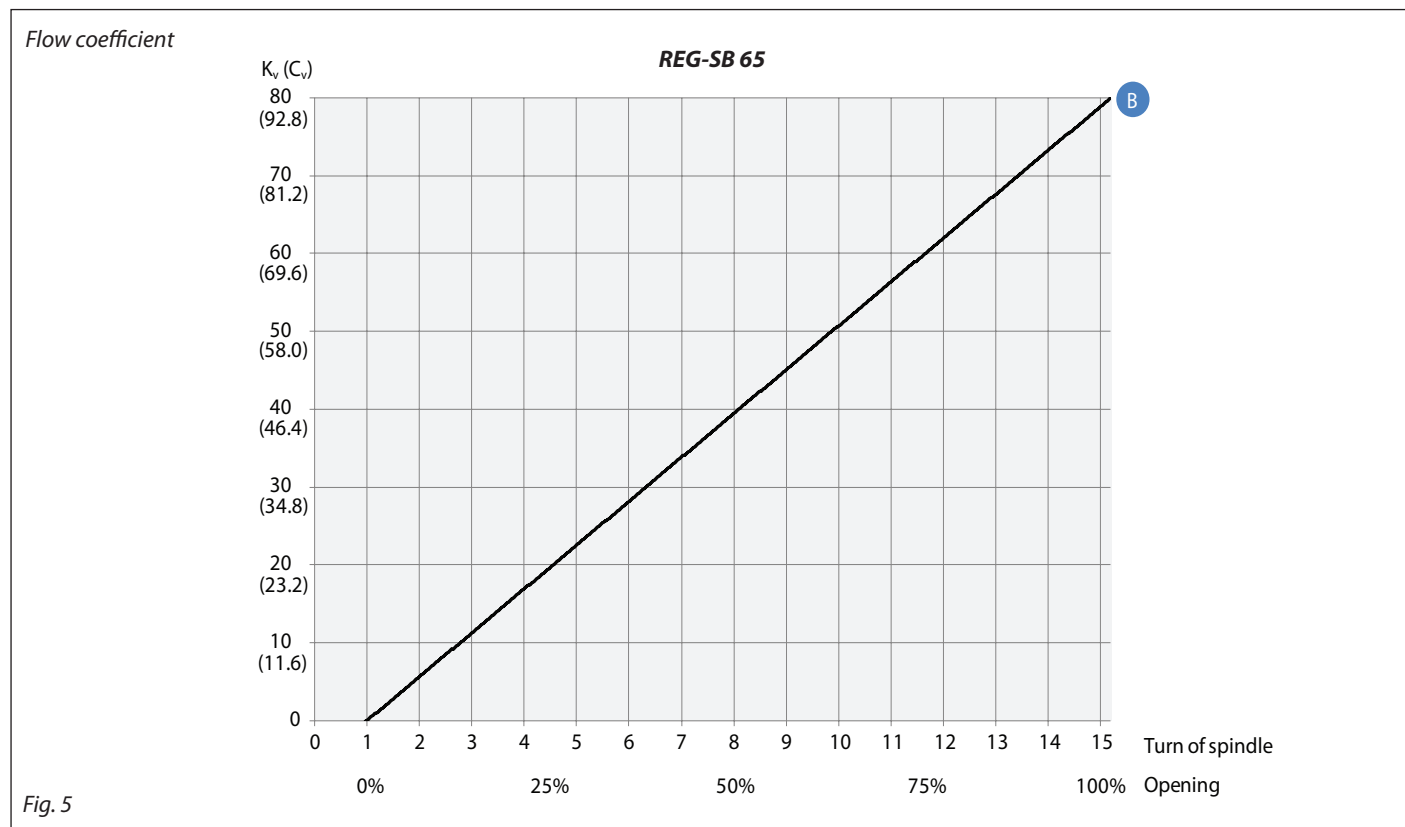

Data sheet | Hand operated regulating valves, types REG-SA and REG-SB

Computation and selection
(Continued)

Liquid R 717, density: 670 kg/m³ [42 lb/ft³]

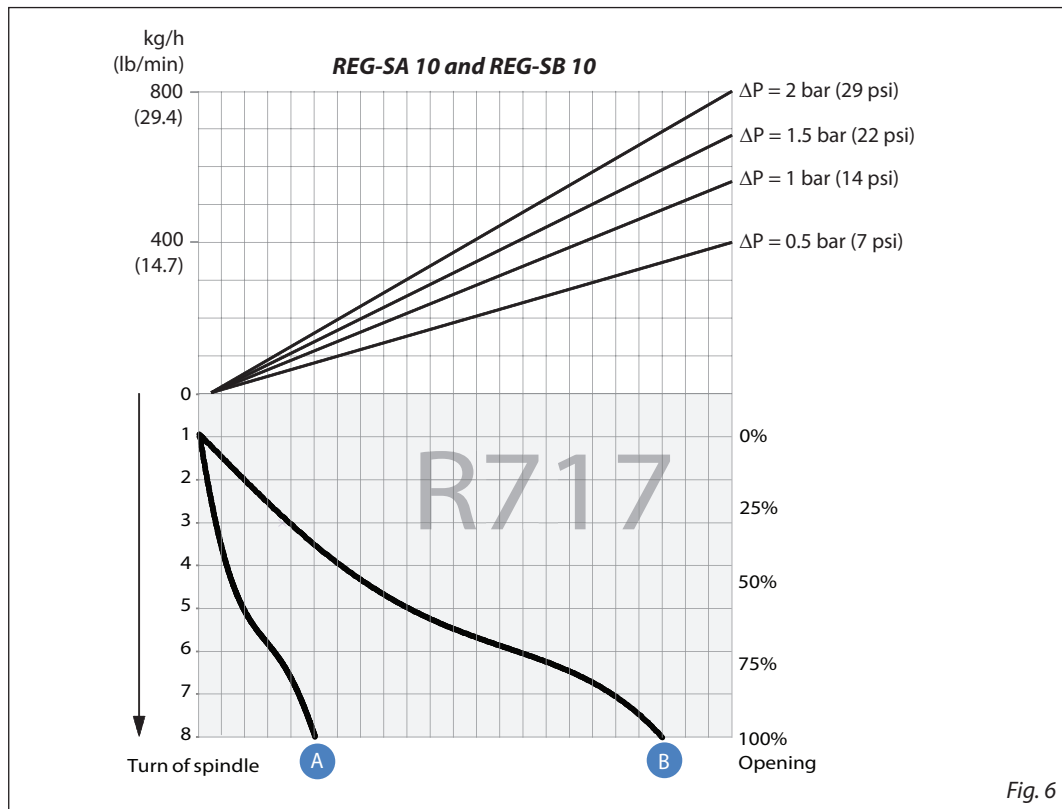

Fig. 6

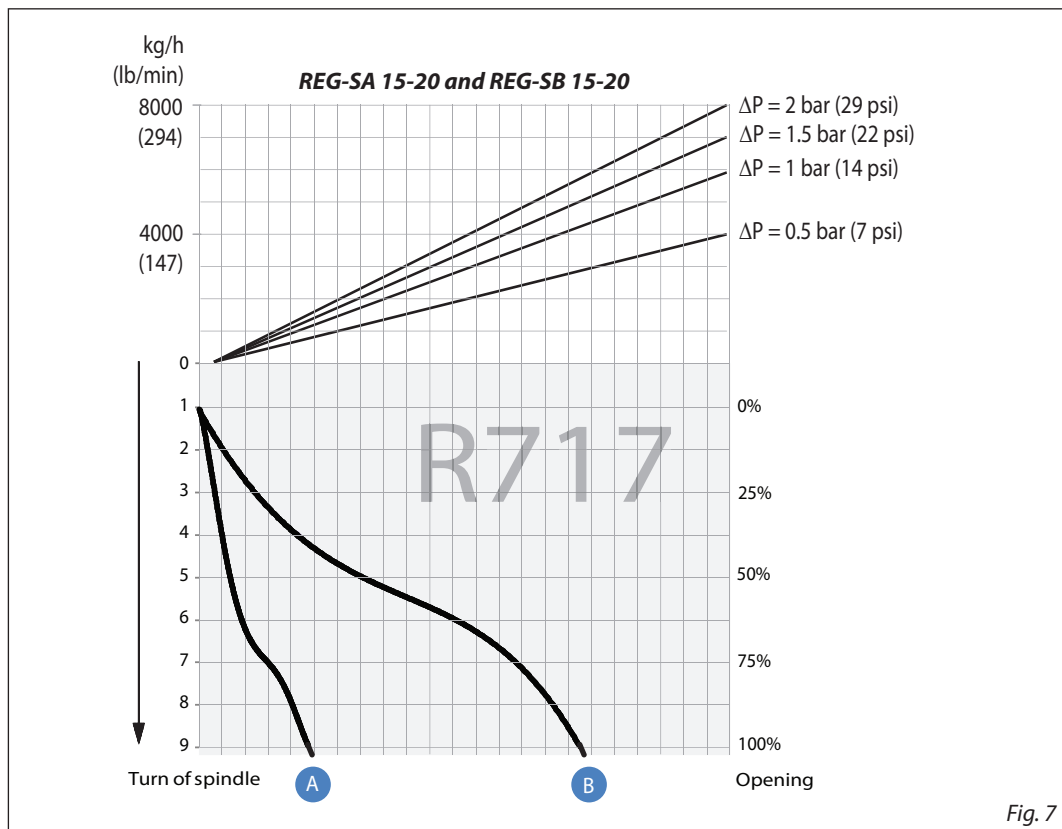

Fig. 7

For choice of valve size and connection see "Connections".

Data sheet | Hand operated regulating valves, types REG-SA and REG-SB

Computation and selection
(Continued)

Liquid R 717, density: 670 kg/m³ [42 lb/ft³]

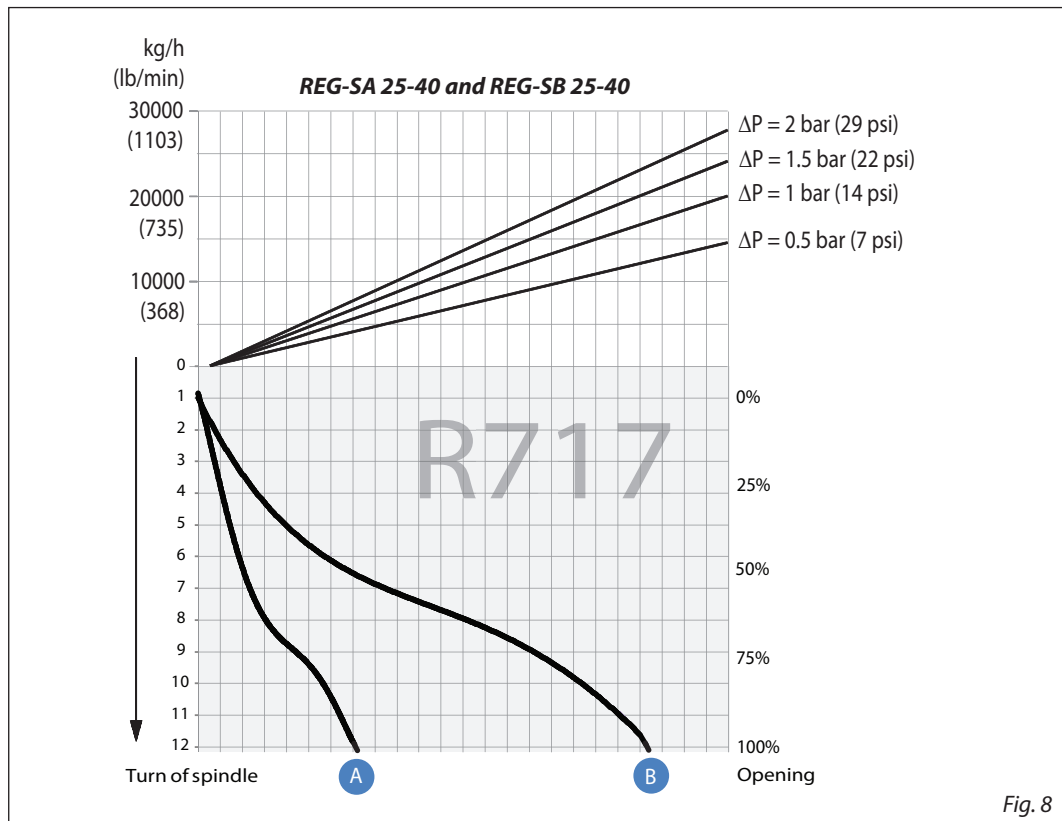

Fig. 8

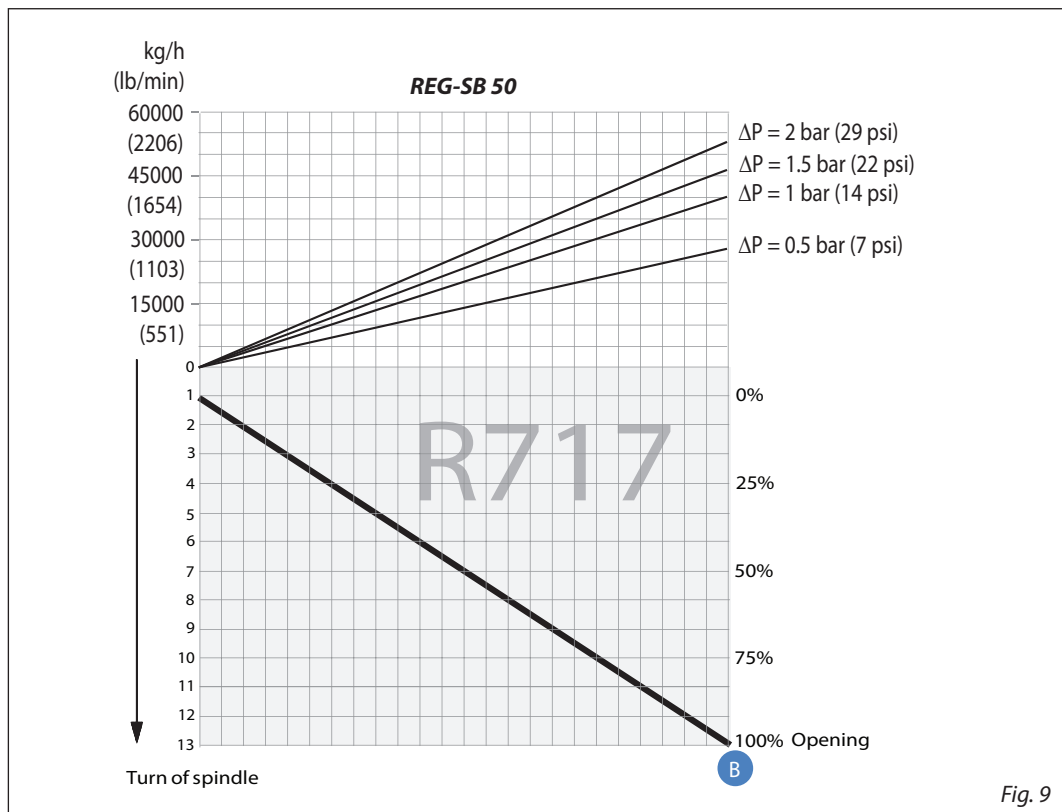

Fig. 9

For choice of valve size and connection see "Connections".

Data sheet | Hand operated regulating valves, types REG-SA and REG-SB

Computation and selection
(Continued)

Liquid R 717, density: 670 kg/m³ [42 lb/ft³]

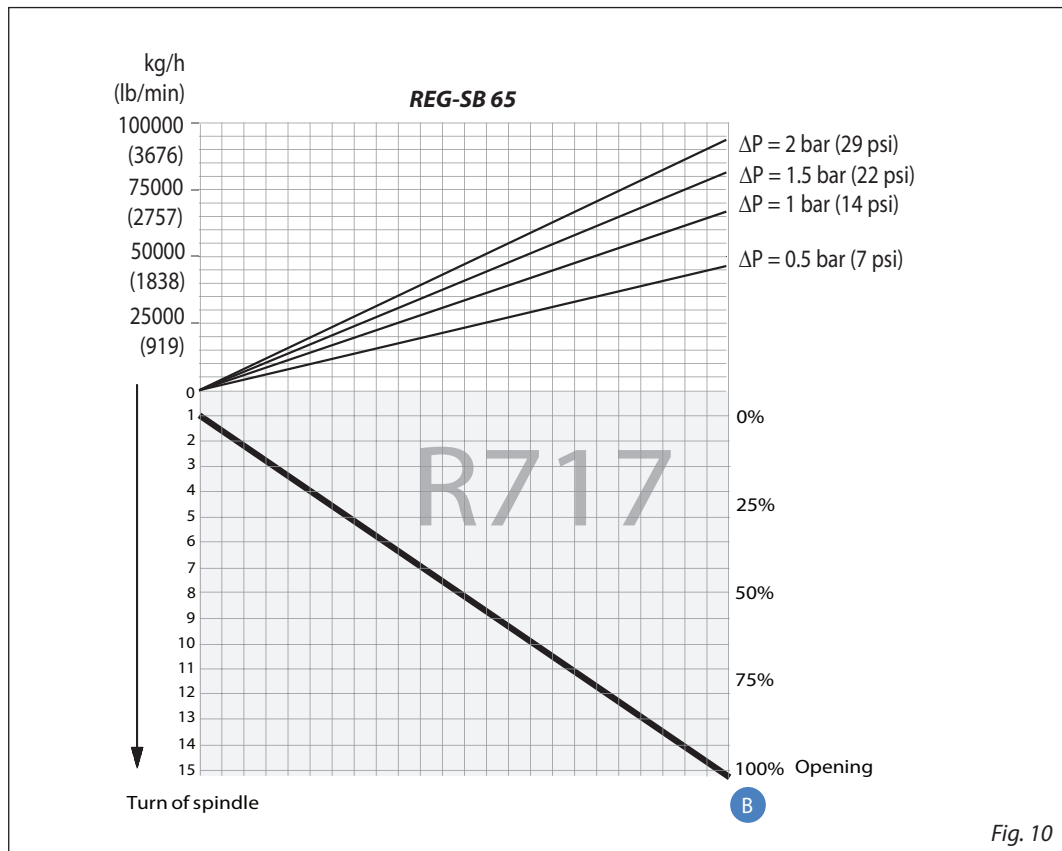

Calculation factor C_A

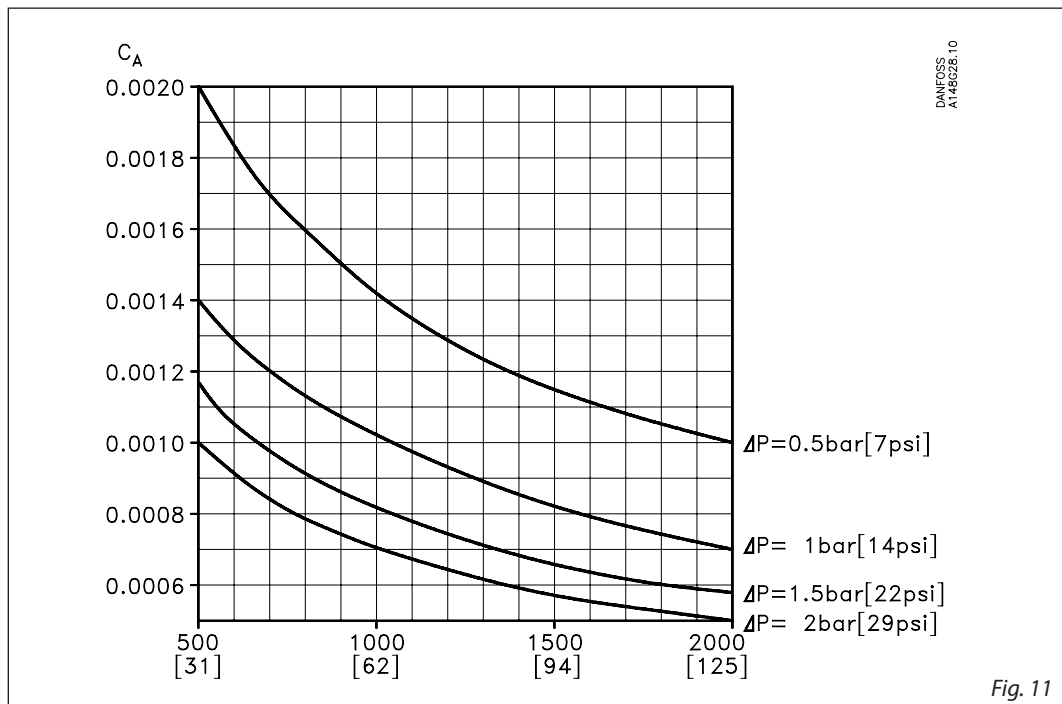

For choice of valve size and connection see "Connections".

Data sheet | Hand operated regulating valves, types REG-SA and REG-SB

Computation and selection

Example 1.

Refrigerant: R 717
 Refrigerant flow: 2200 kg/h
 Pressure drop: $\Delta p = 0.5$ bar

The above mentioned example is illustrated on the following flow rate diagram and shows that REG-SB 15 and 20 with cone B can be used. The main rule is that nominal regulation range should be below 85% opening degree. If the arrowline is crossing 2 cone curves, the smaller cone should be selected if opening degree < 85%.

The example is only correct if the density of the refrigerant is approx. 670 (kg/m³), and there must be no build-up of flash gas in the valve.

Flow rate diagram

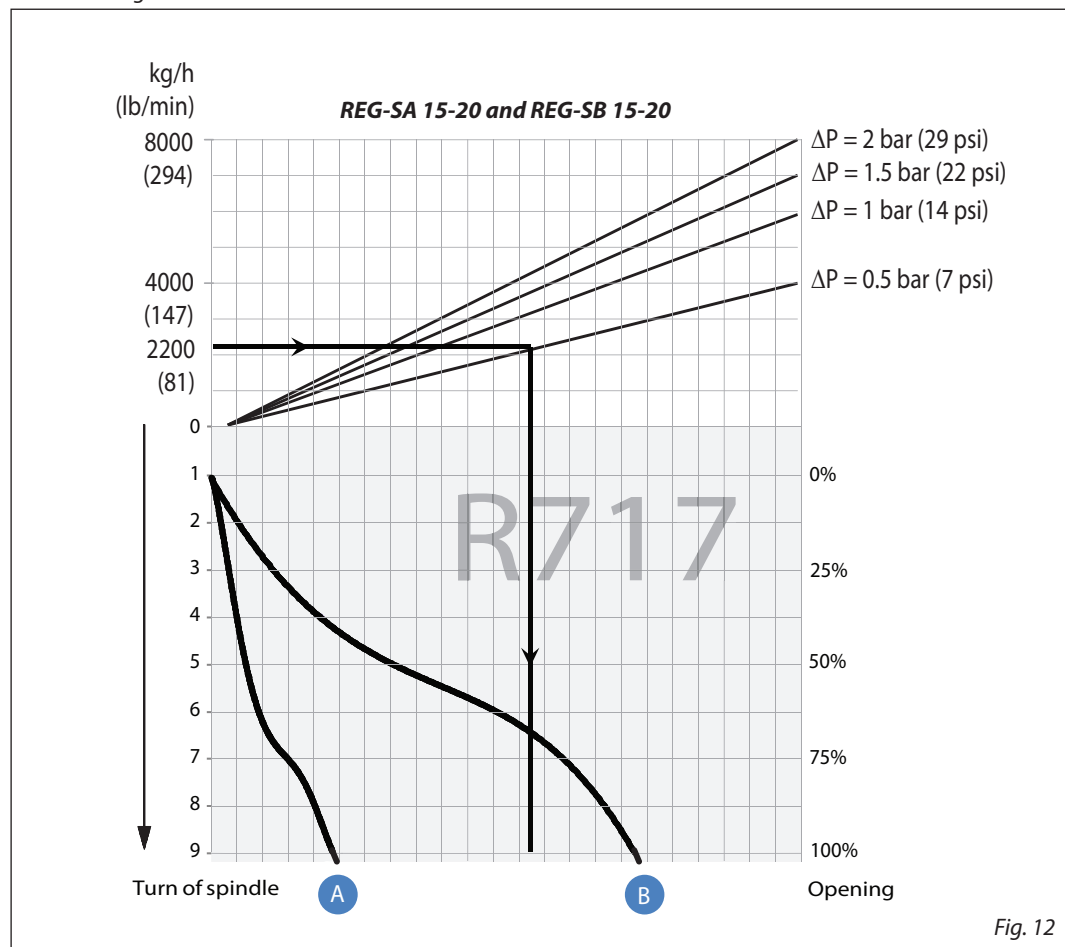

Data sheet | Hand operated regulating valves, types REG-SA and REG-SB

Computation and selection

Example 2.

Brine, density ρ : 1150 [kg/m³]
 Brine flow G: 2,700 [kg/h]
 Pressure drop Δp : 0.5 [bar]

In this example it is not possible to use the selection diagrams (fig. 6 - 10) as the refrigerant in question is not included.

Use the curves of the k_v -values instead (fig. 1 - 5) and calculate the required k_v by means of the formulas in the "Introduction" passage at the beginning of this chapter. Alternatively calculate the k_v -values by means of the calculation factor C_A (fig. 13) and the flow rate diagram (in this example: fig. 14) as per the following calculation example.

Calculation example:

Required k_v -value
 $C_A = 0.00132$ (from fig. 18)
 $k_v = C_A \times G$
 $k_v = 0.00132 \times 2,700$ [kg/h]
 $= 3.56$ [m³/h]

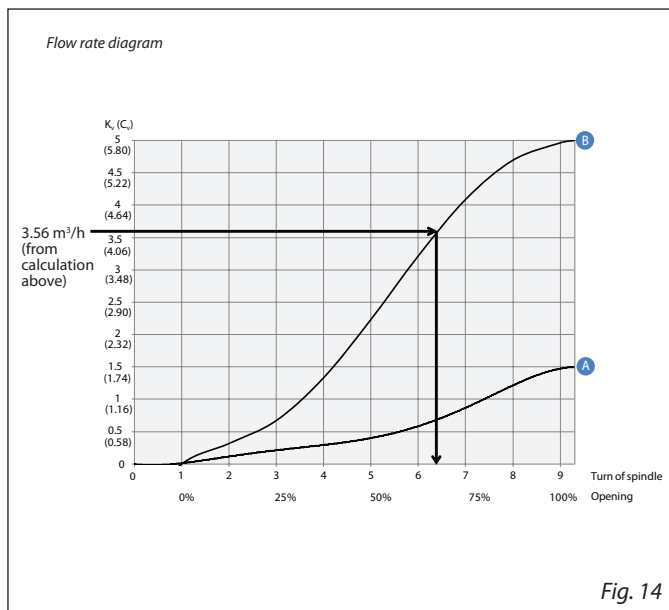
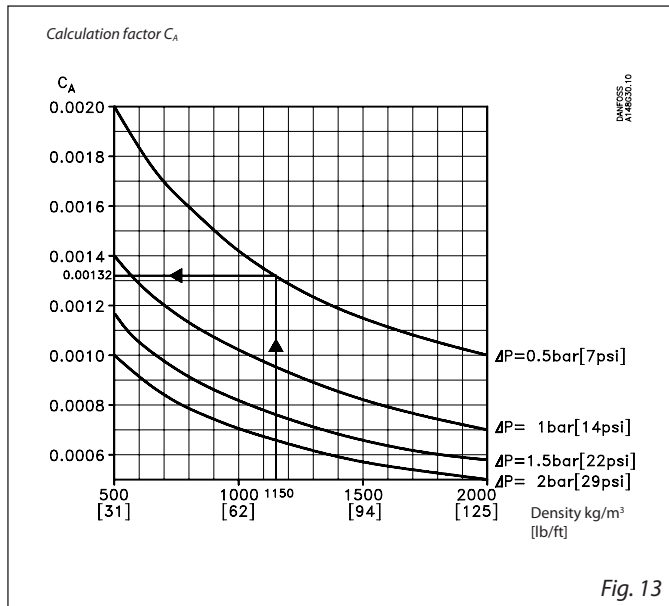

Material specification

REG-SA and REG-SB 10

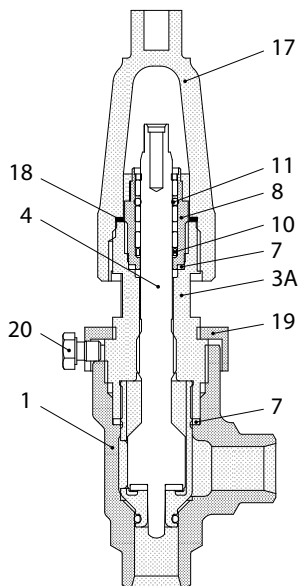

REG-SA and REG-SB 15 - 40

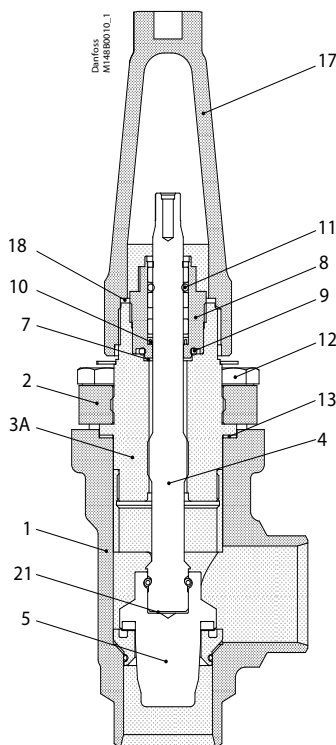

REG-SA and REG-SB 50 - 65

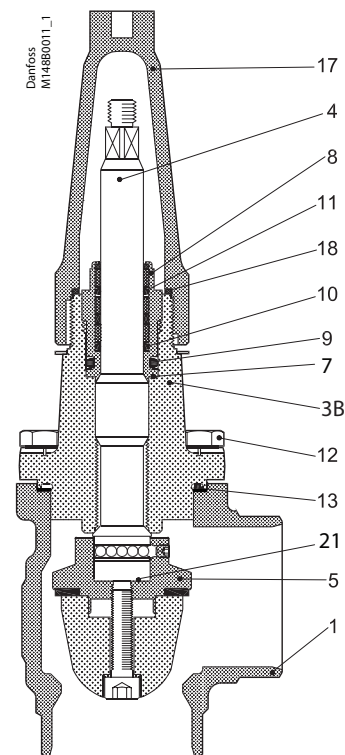

No.	Part	Material	EN	ISO	ASTM
1	Housing	Steel	G20Mn5QT, 10213-3 ----- P285QH+QT, 10222-4		LCC, A352 ----- LF2, A350
2	DN 15 - 40 (½ - 1½ in.) - Bonnet, Flange	Steel	P275 NL EN10028-3		A A662
3A	DN 10 - 40 (¾ - 1½ in.) - Bonnet, Insert	Steel	11SMn30 10087	Type 2, R 683-9	1213 SAE J403
3B	DN 50 - 65 (2 - 2½ in.) - Bonnet, Flange	Steel	P285QH+QT 10222-4		LF2 A350
4	Spindle DN 10 - 65 (¼ - 2½ in.)	Stainless steel	X8CrNiS 18-9, 17440	Type 17, 683/13	AISI 303
5	Cone	Steel			
7	Packing washer	Aluminium			
8	Packing gland	Stainless Steel	X8CrNiS 18-9, 10088	Type 17, 683/13	AISI 303
9	O-ring	Cloroprene (Neoprene)			
10	Spring loaded Teflon ring	PTFE			
11	O-ring	Cloroprene (Neoprene)			
12	Bolts	Stainless steel	A2-70	A2-70	Type 308
13	Gasket	Fiber, non asbestos			
14	Bottom insert	Steel			
17	Seal cap	Aluminium			
18	Gasket f. seal cap	Nylon			
19	Locking nut	Steel			
20	Screw	Steel			
21	Disk spring	Steel			

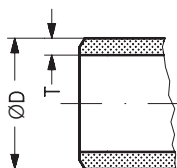
Data sheet | Hand operated regulating valves, types REG-SA and REG-SB
Connections
ANSI

Butt-weld ANSI (B 36.10 Schedule 80)

REG-SA / SB	10	$\frac{3}{8}$	17.2	3.2	0.677	0.126	A and B
REG-SA / SB	15	$\frac{1}{2}$	21.3	3.7	0.839	0.146	A and B
	2	$\frac{3}{4}$	26.9	4.0	1.059	0.158	
REG-SA / SB	25	1	33.7	4.6	1.327	0.181	A and B
	32	$1\frac{1}{4}$	42.4	4.9	1.669	0.193	
	40	$1\frac{1}{2}$	48.3	5.1	1.902	0.201	

Butt-weld ANSI (B 36.10 Schedule 40)

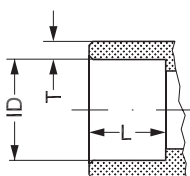
REG-SB	50	2	60.3	3.9	2.37	0.15	B
REG-SB	65	$2\frac{1}{2}$	73.0	5.2	2.87	0.20	B

SOC

Socket welding ANSI (B 16.11)

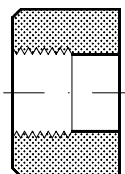
	Size mm	Size in.	ID mm	T mm	ID in.	T in.	L mm	L in.	Cone
REG-SA / SB	15	$\frac{1}{2}$	21.8	6.0	0.858	0.235	10	0.39	A and B
	20	$\frac{3}{4}$	27.2	7.6	1.071	0.299	13	0.51	
REG-SA / SB	25	1	33.9	7.2	1.335	0.284	13	0.51	A and B
	32	$1\frac{1}{4}$	42.7	6.1	1.743	0.240	13	0.51	
	40	$1\frac{1}{2}$	48.8	6.6	1.921	0.260	13	0.51	
REG-SB	50	2	61.2	6.2	2.41	0.24	16	0.63	B

FPT

	Size mm	Size in.	Inside pipe thread	Cone
REG-SA / SB	15	$\frac{1}{2}$	$(\frac{1}{2} \times 14 \text{ NPT})$	A and B
REG-SA / SB	20	$\frac{3}{4}$	$(\frac{3}{4} \times 14 \text{ NPT})$	
REG-SA / SB	25	1	$(1 \times 11.5 \text{ NPT})$	A and B
	32	$1\frac{1}{4}$	$(1\frac{1}{4} \times 11.5 \text{ NPT})$	

FPT inside pipe thread, NPT (ANSI/ASME B 1.20.1)

Dimensions and weights

REG-SA and REG-SB 10 - 65 in angleway version

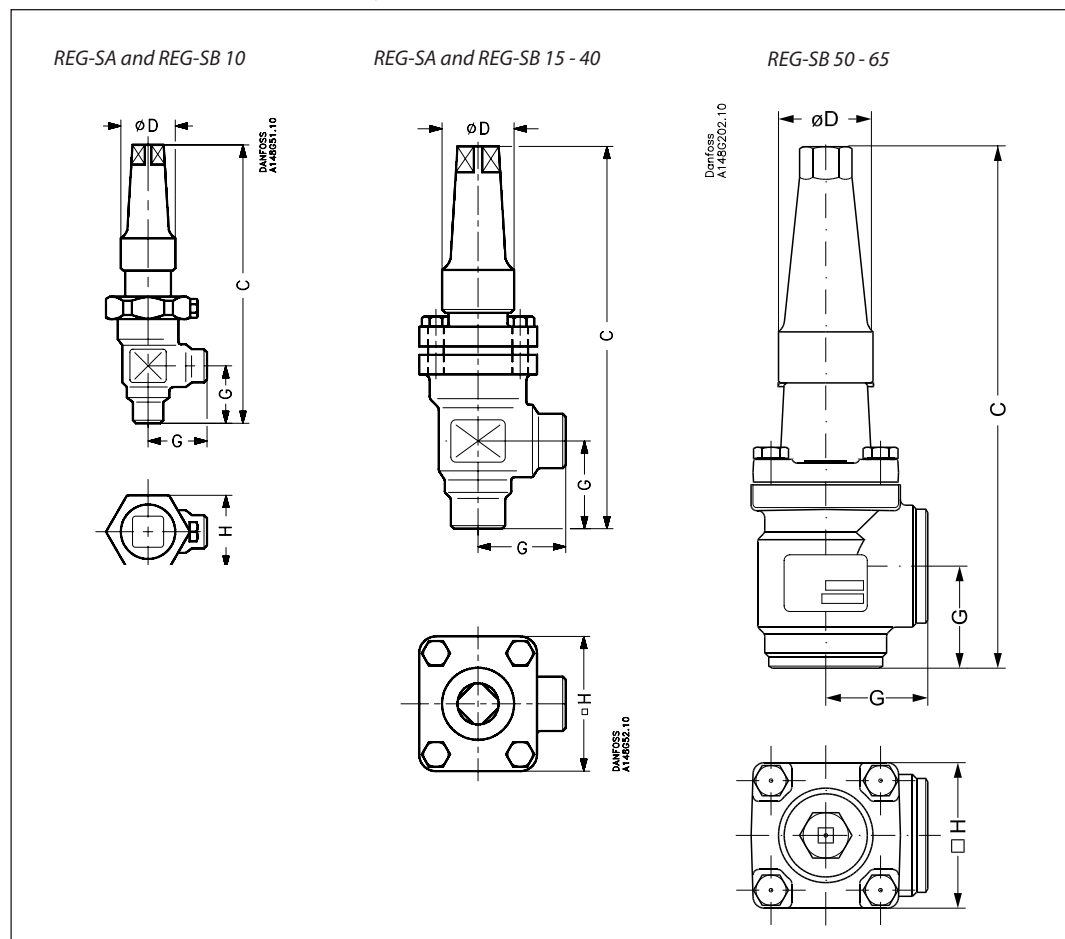

Valve size		C	G	∅D	□H	Weight
REG-SA/SB 10	mm	139	30	30	36	0.8 kg
REG-SA/SB (3/8)	in.	5.47	1.18	1.18	1.42	1.8 lb
REG-SA/SB 15-20	mm	182	45	38	60	1.4 kg
REG-SA/SB (1/2-3/4)	in.	7.17	1.77	1.50	2.36	3.1 lb
REG-SA/SB 25-40	mm	237	55	50	70	2.4 kg
REG-SA/SB (1-1 1/2)	in.	9.33	2.17	1.97	2.76	5.3 lb
REG-SB 50	mm	315	60	50	77	3.2 kg
REG-SB (2 in.)	in.	12.4	2.36	1.97	3.03	7.1 lb
REG-SB 65	mm	335	70	50	90	4.8 kg
REG-SB (2 1/2 in.)	in.	13.19	2.76	1.97	3.54	10.6 lb
REG-SA/SB 32 SOC	mm	275	62	50	70	2.9 kg
REG-SA/SB (1 1/4 in.) SOC	in.	10.83	2.44	1.97	2.76	6.4 lb
REG-SA/SB 40 SOC	mm	275	62	50	70	2.9 kg
REG-SA/SB (1 1/2 in.) SOC	in.	10.83	2.44	1.97	2.76	6.4 lb
REG-SB 50 SOC	mm.	320	65	50	77	4.1 kg
REG-SB (2 in.) SOC	in.	12.60	2.56	1.97	3.03	9.0 lb

Specified weights are approximate values only.

Data sheet | Hand operated regulating valves, types REG-SA and REG-SB

Dimensions and weights
(cont.)

REG-SA and REG-SB 10 - 65 in straightway version

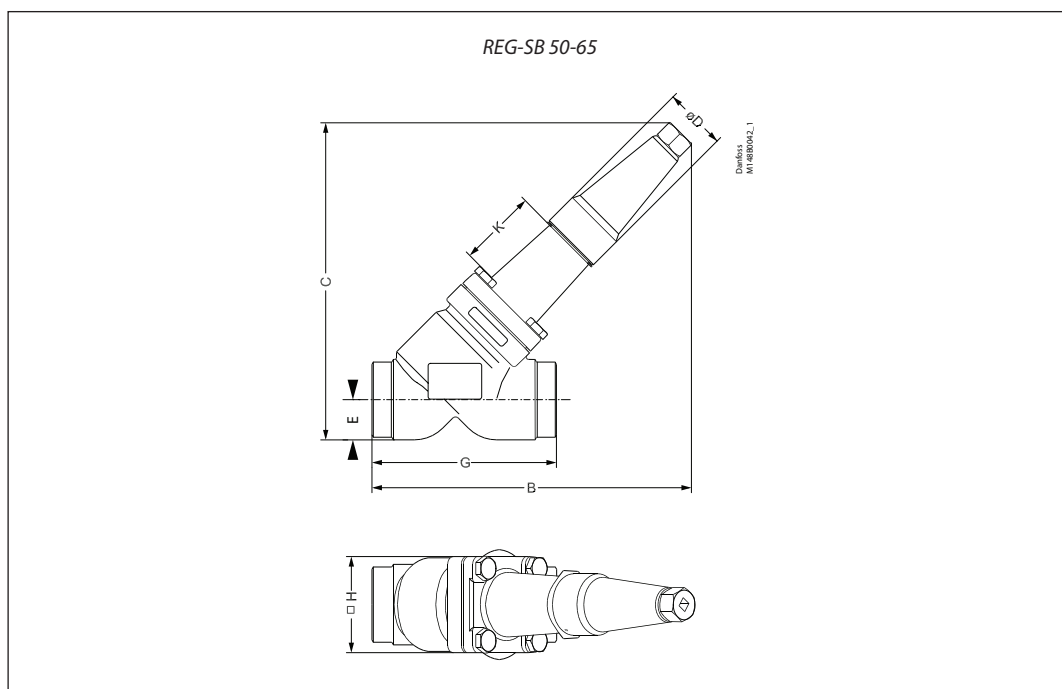
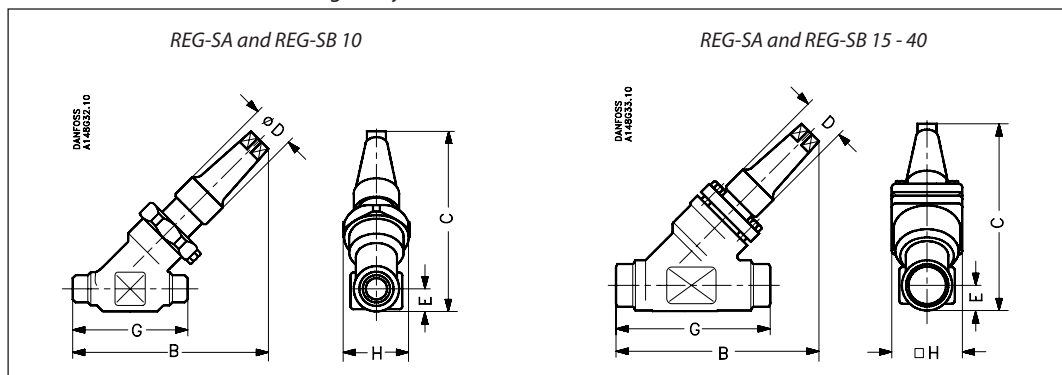

Valve size		C	B	E	G	ØD	□H	Weight
REG-SA/SB 10	mm	110	120	13	70	30	36	0.8 kg
REG-SA/SB (3/8)	in.	4.33	4.72	0.51	2.76	1.18	1.42	1.8 lb
REG-SA/SB 15-20	mm	145	155	20	120	38	60	2.0 kg
REG-SA/SB (1/2-3/4)	in.	5.71	6.10	0.79	4.72	1.50	2.36	4.4 lb
REG-SA/SB 25-40	mm	200	215	26	155	50	70	3.0 kg
REG-SA/SB (1-1 1/2)	in.	7.87	8.46	1.02	6.10	1.97	2.76	6.6 lb
REG-SB 50	mm	257	250	32	148	50	77	4.2 kg
REG-SB (2 in.)	in.	10.12	10.20	1.26	5.83	1.97	3.03	9.3 lb
REG-SB 65	mm	280	284	40	176	50	90	6.3 kg
REG-SB (2 1/2 in.)	in.	11.02	11.18	1.57	6.93	1.97	3.54	13.9 lb
REG 32 SOC	mm	209	222	27.4	155	50	70	3.0 kg
REG (1 1/4) SOC	in.	8.23	8.74	1.08	6.10	1.97	2.76	6.6 lb
REG 40 SOC	mm	213	222	31.0	155	50	70	3.0 kg
REG (1 1/2) SOC	in.	8.39	8.74	1.22	6.10	1.97	2.76	6.6 lb
REG-SB 50 SOC	mm	261	266	37	162	50	77	5.1 kg
REG-SB (2 in.) SOC	in.	10.28	10.47	1.26	6.38	6.38	3.03	11.2 lb

Specified weights are approximate values only.

Data sheet | Hand operated regulating valves, types REG-SA and REG-SB

Ordering

How to order

The table below is used to identify the valve required.

Please note that the type codes only serve to identify the valves, some of which may not form part of the standard product range. For further information please contact your local Danfoss Sales Company.

Type codes

Valve type	REG	Hand operated regulating valves
Nominal size in mm (Valve size measured on the connection diameter)	10 15 20 22 25 32 40 50 65	Available connection types A SOC FPT DN 10 x DN 15 x x x DN 20 x x x DN 22 DN 25 x x x DN 32 x x x DN 40 x x DN 50 x x DN 65 x
Connections	A	Welding branches: ANSI B 36.10 schedule 80, 15 - 40 (½ - 1½ in.) Welding branches: ANSI B 36.10 schedule 40, 50 - 65 (2 - 2½ in.)
	SOC	Socket weld: ANSI B 16.11
	FPT	NPT inside pipe thread: ANSI/ASME B1.20.1
Valve housing	ANG	Angle flow
	STR	Straight flow
Cone A	Size: DN 10 DN 15 DN 20 DN 25 DN 32 DN 40	Flow area [mm ²] 3.02 36.5 36.5 178 178 178
Cone B	Size: DN 10 DN 15 DN 20 DN 25 DN 32 DN 40 DN 50 DN 65	Flow area [mm ²] 16 115 115 531 531 531 822 1978

Available combination between valve size, cone type and valve connection

Size	DN 10 (¾")		DN 15 (½")		DN 20 (¾")		DN 22 (7/8")		DN 25 (1")		DN 32 (1¼")		DN 40 (1½")		DN 50 (2")		DN 65 (2½")		
	A	B	A	B	A	B	A	B	A	B	A	B	A	B	A	B	A	B	
ANSI	x	x	x	x	x	x			x	x	x	x	x	x		x			x
SOC			x	x	x	x			x	x	x	x	x	x		x			
FPT			x	x	x	x			x	x	x	x							

x = available

Ordering
(continued)
Important!

Where products need to be certified according to specific certification societies or where higher pressures are required, the relevant information should be included at the time of order.

Complete REG-SA (Cone type A)
Butt-weld ANSI (B 36.10 Schedule 80)

Size		Type	Code no.
mm	in.		

Angleway - REG-SA with cone type A

10	3/8	REG-SA 10 A ANG	148B5106
15	1/2	REG-SA 15 A ANG	148B5202
20	3/4	REG-SA 20 A ANG	148B5302
25	1	REG-SA 25 A ANG	148B5402
32	1 1/4	REG-SA 32 A ANG	148B5502
40	1 1/2	REG-SA 40 A ANG	148B5602

Butt-weld ANSI (B 36.10 Schedule 80)

Size		Type	Code no.
mm	in.		

Straightway - REG-SA with cone type A

10	3/8	REG-SA 10 A STR	148B5116
15	1/2	REG-SA 15 A STR	148B5212
20	3/4	REG-SA 20 A STR	148B5312
25	1	REG-SA 25 A STR	148B5412
32	1 1/4	REG-SA 32 A STR	148B5512
40	1 1/2	REG-SA 40 A STR	148B5612

Socket welding ANSI (B 16.11)

Size		Type	Code no.
mm	in.		

Angleway - REG-SA with cone type A

15	1/2	REG-SA 15 SOC ANG	148B5204
20	3/4	REG-SA 20 SOC ANG	148B5304
25	1	REG-SA 25 SOC ANG	148B5404
32	1 1/4	REG-SA 32 SOC ANG	148B5504
40	1 1/2	REG-SA 40 SOC ANG	148B5604

Socket welding ANSI (B 16.11)

Size		Type	Code no.
mm	in.		

Straightway - REG-SA with cone type A

15	1/2	REG-SA 15 SOC STR	148B5214
20	3/4	REG-SA 20 SOC STR	148B5314
25	1	REG-SA 25 SOC STR	148B5414
32	1 1/4	REG-SA 32 SOC STR	148B5514
40	1 1/2	REG-SA 40 SOC STR	148B5614

FPT inside pipe thread, NPT (ANSI/ASME B 1.20.1)

Size		Type	Code no.
mm	in.		

Angleway - REG-SA with cone type A

15	1/2	REG-SA 15 FTP ANG	148B5206
20	3/4	REG-SA 20 FTP ANG	148B5306
25	1	REG-SA 25 FTP ANG	148B5406
32	1 1/4	REG-SA 32 FTP ANG	148B5506

FPT inside pipe thread, NPT (ANSI/ASME B 1.20.1)

Size		Type	Code no.
mm	in.		

Straightway - REG-SA with cone type A

15	1/2	REG-SA 15 FTP STR	148B5216
20	3/4	REG-SA 20 FTP STR	148B5316
25	1	REG-SA 25 FTP STR	148B5416
32	1 1/4	REG-SA 32 FTP STR	148B5516

A = Butt-weld ANSI
 SOC = Socket weld
 FPT = Inside pipe thread

ANG = Angleway
 STR = Straightway

Ordering
(continued)
Important!

Where products need to be certified according to specific certification societies or where higher pressures are required, the relevant information should be included at the time of order.

Complete REG-SB (Cone type B)
Butt-weld ANSI (B 36.10 Schedule 80)

Size		Type	Code no.
mm	in.		

Angleway - REG-SB with cone type B

10	3/8	REG-SB 10 A ANG	148B5107
15	1/2	REG-SB 15 A ANG	148B5203
20	3/4	REG-SB 20 A ANG	148B5303
25	1	REG-SB 25 A ANG	148B5403
32	1 1/4	REG-SB 32 A ANG	148B5503
40	1 1/2	REG-SB 40 A ANG	148B5603

Butt-weld ANSI (B 36.10 Schedule 80)

Size		Type	Code no.
mm	in.		

Straightway - REG-SB with cone type B

10	3/8	REG-SB 10 A STR	148B5117
15	1/2	REG-SB 15 A STR	148B5213
20	3/4	REG-SB 20 A STR	148B5313
25	1	REG-SB 25 A STR	148B5413
32	1 1/4	REG-SB 32 A STR	148B5513
40	1 1/2	REG-SB 40 A STR	148B5613

Butt-weld ANSI (B 36.10 Schedule 40)

Size		Type	Code no.
mm	in.		

Angleway - REG-SB with cone type B

50	2	REG-SB 50 A ANG	148B5706
65	2 1/2	REG-SB 65 A ANG	148B5806

Butt-weld ANSI (B 36.10 Schedule 40)

Size		Type	Code no.
mm	in.		

Straightway - REG-SB with cone type B

50	2	REG-SB 50 A STR	148B5724
65	2 1/2	REG-SB 65 A STR	148B5809

Socket welding ANSI (B 16.11)

Size		Type	Code no.
mm	in.		

Angleway - REG-SB with cone type B

15	1/2	REG-SB 15 SOC ANG	148B5205
20	3/4	REG-SB 20 SOC ANG	148B5305
25	1	REG-SB 25 SOC ANG	148B5405
32	1 1/4	REG-SB 32 SOC ANG	148B5505
40	1 1/2	REG-SB 40 SOC ANG	148B5605
50	2	REG-SB 50 SOC ANG	148B5727

Socket welding ANSI (B 16.11)

Size		Type	Code no.
mm	in.		

Straightway - REG-SB with cone type B

15	1/2	REG-SB 15 SOC STR	148B5215
20	3/4	REG-SB 20 SOC STR	148B5315
25	1	REG-SB 25 SOC STR	148B5415
32	1 1/4	REG-SB 32 SOC STR	148B5515
40	1 1/2	REG-SB 40 SOC STR	148B5615
50	2	REG-SB 50 SOC STR	148B5725

FPT inside pipe thread, NPT (ANSI/ASME B 1.20.1)

Size		Type	Code no.
mm	in.		

Angleway - REG-SB with cone type B

15	1/2	REG-SB 15 FTP ANG	148B5207
20	3/4	REG-SB 20 FTP ANG	148B5307
25	1	REG-SB 25 FTP ANG	148B5407
32	1 1/4	REG-SB 32 FTP ANG	148B5507

FPT inside pipe thread, NPT (ANSI/ASME B 1.20.1)

Size		Type	Code no.
mm	in.		

Straightway - REG-SB with cone type B

15	1/2	REG-SB 15 FTP STR	148B5217
20	3/4	REG-SB 20 FTP STR	148B5317
25	1	REG-SB 25 FTP STR	148B5417
32	1 1/4	REG-SB 32 FTP STR	148B5517

A = Butt-weld ANSI
 SOC = Socket weld
 FPT = Inside pipe thread

ANG = Angleway
 STR = Straightway

Data sheet | Hand operated regulating valves, types REG-SA and REG-SB

Ordering REG-SA/SB from the parts programme

Example

(select from table 1 and 2)

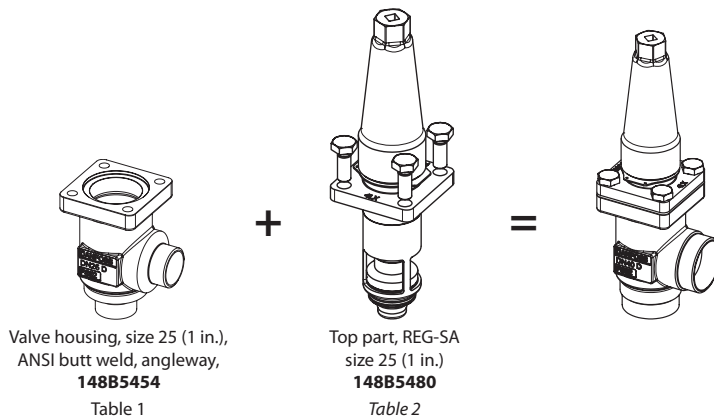

Table 1
SVL valve housings w/different connections

Sizes [DN]		DN 10 mm ($\frac{3}{8}$ in.)				DN 15-65 mm ($\frac{1}{2}$ - 2½ in.)			
		ANSI-Butt weld		SOC		FPT			
mm	in.	ANG	STR	ANG	STR	ANG	STR	ANG	STR
10	$\frac{3}{8}$	148B5124	148B5125						
15	$\frac{1}{2}$	148B5254	148B5255	148B5256	148B5257	148B5258	148B5259		
20	$\frac{3}{4}$	148B5354	148B5355	148B5356	148B5357	148B5358	148B5359		
25	1	148B5454	148B5455	148B5456	148B5457	148B5458	148B5459		
32	1¼	148B5578	148B5579	148B5580	148B5581	148B5582	148B5583		
40	1½	148B5654	148B5655	148B5656	148B5657				
50	2	148B5743	148B5744	148B5745	148B5746				
65	2½	148B5818	148B5819	148B5816	148B5817				

Table 2
REG complete top part including gaskets and bolts

Sizes [DN]		REG-SA/SB 10	REG-SA/SB 15-65	REG-LA/LB 15-40	
		Complete top part			
mm	in.	REG-SA	REG-SB	REG-LA	REG-LB
10	$\frac{3}{8}$	148B5112	148B5113		
15	$\frac{1}{2}$	148B5280	148B5281	148B6401	148B6402
20	$\frac{3}{4}$				
25	1	148B5480	148B5481	148B6403	148B6404
32	1¼				
40	1½				
50	2		148B5734		
65	2½		148B5824		

Replacement kit (O-ring replacement) for R717 Ammonia Heat Pump* and Propylene applications (including ID tag)

Size (DN)		O-ring kit for	
mm	in.	R717 Heat pump	R1270 Propylene
10	$\frac{3}{8}$	148B6084	148B6085
15	$\frac{1}{2}$	148B6070	148B6077
20	$\frac{3}{4}$		
25	1	148B6096	148B6097
32	1¼		
40	1½		

* Replacement kits for R717 Ammonia Heat Pump is applicable for continuous operating temperature between +100 °C to 150 °C (212 °F to 302 °F)

ENGINEERING
TOMORROW



Danfoss can accept no responsibility for possible errors in catalogues, brochures and other printed material. Danfoss reserves the right to alter its products without notice. This also applies to products already on order provided that such alterations can be made without subsequential changes being necessary in specifications already agreed. All trademarks in this material are property of the respective companies. Danfoss and the Danfoss logotype are trademarks of Danfoss A/S. All rights reserved.